

## Operating Instruction

### For Hermle Skeleton Movement W701 / W791 automatic anchor

Open carton and unpack clock carefully. Take off any transportation security device (rubber band, foam rubber on pendulum intermediate part and chain).

#### Starting the clock:

Hang clock on the wall and be sure that clock hangs vertically (straight).

The chain has a ring on one end and a hook on the other. Above the hook you will find a stop ring. Hang weight to the hook of the chain and pull chain down slowly until the stop ring on the hook side is touching the case. Clock is now fully wound.

The anchor with the pendulum intermediate part is at the back of the movement. The end of the pendulum intermediate part has a special opening for the hook of the pendulum stick (see sketch). Be sure that pendulum is correctly positioned (polished / brushed part has to be at the front of the clock). Move pendulum gently to one side until pendulum stick is touching the opening of the case and release it. If clock stops after a few minutes repeat the same procedure.

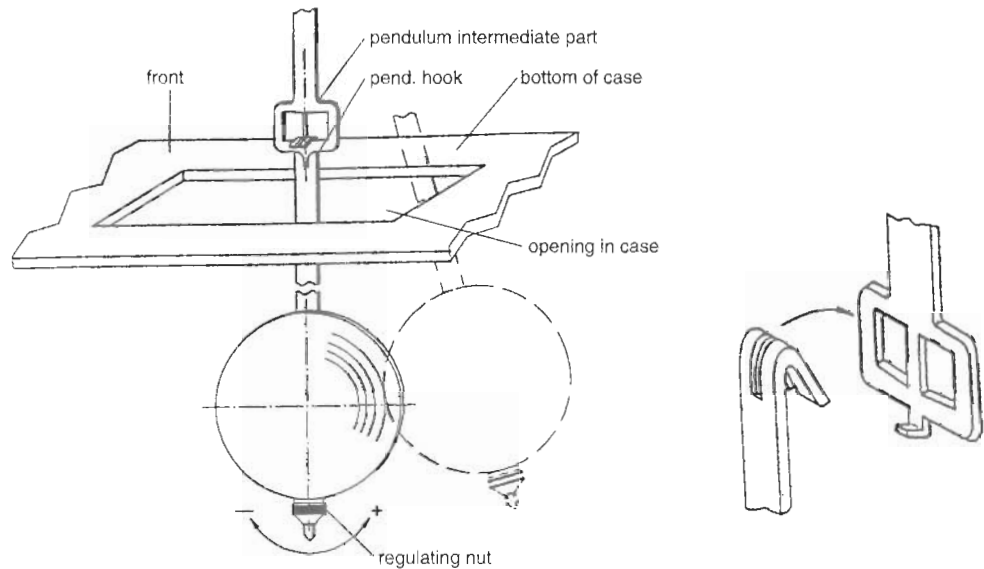

To set the correct time move minute hand (long hand) to the desired time. This can be done clockwise or counter-clockwise. On every full hour the clock will strike once. If the weight is fully up the clock will run approx. one week. Please pull up the weight regularly as mentioned above.

#### Regulating of the clock:

If it is necessary to adjust clock for accurate time-keeping turn the regulating nut underneath the pendulum disc to the right if clock runs too slow or to the left if clock runs too fast (one full turn = approx. 45 seconds per day). Hold pendulum disc so that pendulum stick won't be twisted.